



OPERATOR'S GUIDE

SnagPod

James Heal
Halifax, England

Publication 290-726\$F

©2017

Setting the Standard

Published by:

PPT GROUP
Trading as JAMES HEAL
RICHMOND WORKS
HALIFAX
WEST YORKSHIRE
HX3 6EP
UNITED KINGDOM

James Heal is a PPT Group brand.

PPT Group UK Ltd is a company registered in England and Wales, company number 414668.

TELEPHONE +44 (0) 1422 366355

E-mail Halifaxinformation@pptgroup.com

Internet <http://www.james-heal.co.uk>

© 2017

INTRODUCTION

Scope

This test is designed to determine propensity to surface defects by a snagging mechanism, of textile fabrics. The test is suitable for knitted and woven structures. Filament yarns, textured or untextured are usually more prone to snagging but staple yarns in certain types of design structures can also be prone to snagging.

The Definition of Snagging

Snagging is a term used to describe undesirable surface deterioration effects such as filamentation or looping. The breaking of individual threads in a woven or knitted fabric causes the generation of this type of surface damage.

Orbitor Model Range

There are two standard instruments, one with 2-test positions and one with 4-test positions. To offer complete flexibility and choice, the two basic instruments can be fitted with any of the following test chambers:

- Pilling Box
- Pilling Drum
- SnagPod
- Snagging Box
- Snagging Drum

For safety reasons, Orbitor features a common drive system, therefore it is not possible to run test chambers at different speeds simultaneously.

Key features

The SnagPod fits in place of a test box or test drum on a James Heal's Pilling Tester or on a later generation Orbitor.

The SnagPod is Octagonal in shape.

Inside there are 4 snagging bars.

The pins are inclined in the direction of rotation.

Four specimens are tested simultaneously.

The specimens are mounted on felt covered polyurethane tubes.

After testing, the specimens are compared against a series of standard photographs and are assigned a numerical rating.

INSTALLATION

Health and Safety

The SnagPod weighs approximately 7.5kg, therefore it is suitable for lifting by a single person if using safe working practices.

SnagPod complies with the CE regulations in full.

Ensure all test chambers are secure before commencing a test.

Ensure all lids to the test chambers are secure before commencing a test.

Keep clear of all moving parts when the test chambers are rotating.

Never use SnagPod for anything other than what it is designed for.

Unpacking Checklist

Do not dispose of any packaging material until all accessories have been accounted for. If there are any discrepancies please contact your supplier immediately.

Remove the tape from the outer packing.

Lift out the top box containing the accessories. Remove the tape and ensure that all accessories are present.

Remove the lid from the lower section.

Carefully remove the SnagPod from the packing case and place on a firm, flat surface.

Identification of Parts

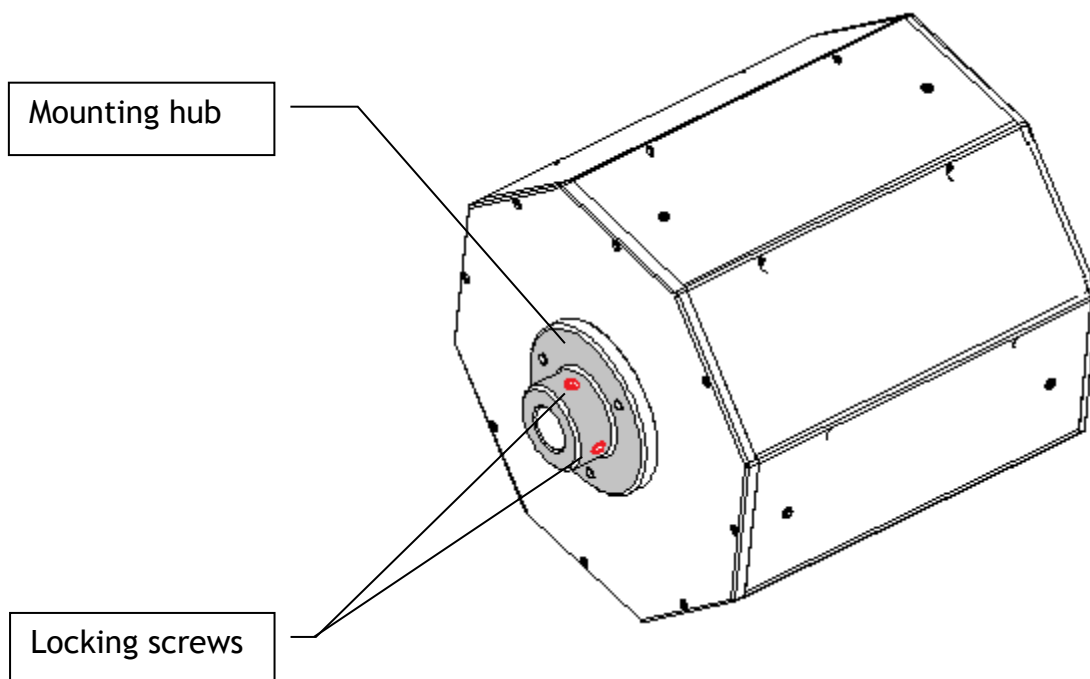

How to Order

794-726 SnagPod

Standard Accessories

758-554 2 × Pack (4) Felt covered polyurethane tubes
758-553 1 Pack (20) Locking rings
772-121 1 Specimen Template
766-455 1 Set (9) reference photo's
766-480 1 Assessment mask
319-152 1 Pack (10) Fixing screws for Snagging Bars

Assessment

708-925 VeriVide Assessment Viewer 220/230V 50/60 Hz
708-930 VeriVide Assessment Viewer 110V 50/60 Hz

Spares and Test Materials

794-824 Spare Snagging Bar
319-152 Pack (10) spare fixing screws for snagging bars
758-554 1 Pack (4) Felt covered Polyurethane tube
758-553 Pack (20) Locking rings
766-455 1 Set (9) reference photo's
772-121 1 Specimen Template
766-480 1 Assessment mask

GETTING STARTED

Mounting the Pod

Extract the locking screws (2 per box) using the 4mm ball driver provided. The locking screws can be found on the circular hub. Align the test chamber with the drive shaft, ensuring the locking screws are aligned with the dimples on the shaft. Gently slide the test chamber onto the shaft ensuring the mounting hub is fully engaged. Tighten both locking screws using reasonable force. It is important that the locking screws are fully engaged in the dimples on the drive shaft. After several hundred revolutions the test chamber may self-align causing the locking screws to become loose. At a convenient time, re-tighten the locking screws. Periodically check the screws are tight. **NEVER lift the machine by the SnagPod. This will result in damage to the instrument.**

Removing SnagPod

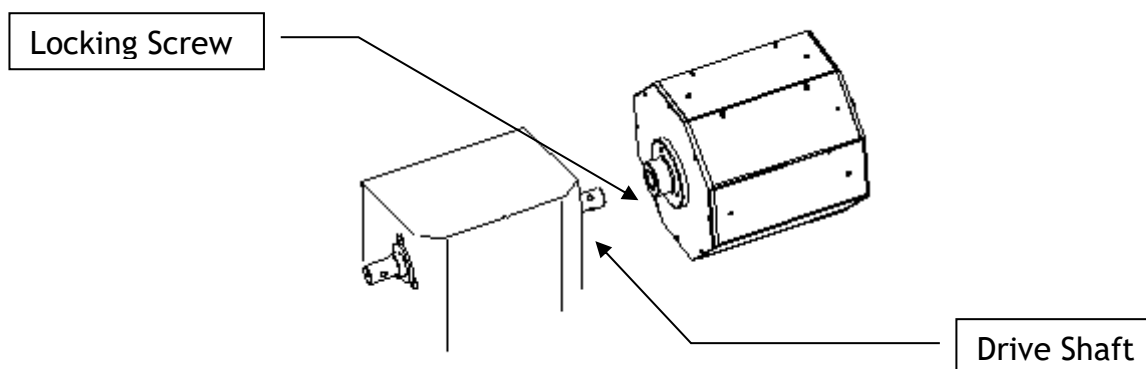

SnagPod can be removed simply by fully unscrewing the locking screws using the 4mm hexagon key. When the screws are fully retracted, carefully slide the box off the end of the shaft. Ensure both drive shaft and mounting flange are clean before reassembly.

Fitting/Changing Snagging Bars

Safety - isolate the machine from the mains electrical supply and disconnect the mains lead before removing the Pin Bars

- Remove the two screws holding the pin bar in place using a 2.5mm hexagon key. These can be accessed from outside of the SnagPod.
- Carefully pull the pin-bar from the pocket in the SnagPod wall. It is advisable to wear a pair of leather gloves.

Caution: the pins are very sharp.

- Fit or replace the pin-bar ensuring the pins are facing in the correct direction i.e., forward inclined in the direction of rotation.
- Re-assemble the fixing screws and tighten.

Caution: do not over tighten the fixing screws. Periodically check the screws for tightness.

Note: if the pin-bars are difficult to remove. Insert the fixing screws and engage the threads with several turns. Push on the heads of the screws and this in turn will push the pin-bar out of the pocket. Take care not to damage the screw threads.

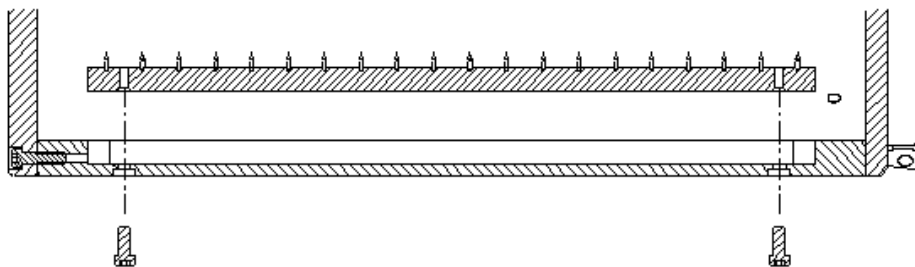

Correct Fitment of SnagPod Pin Bars

The SnagPod pins should be fitted so that they point in the direction of rotation of the SnagPod.

When fitted **correctly** the test sample will hit the point of the pin giving **correct** results.

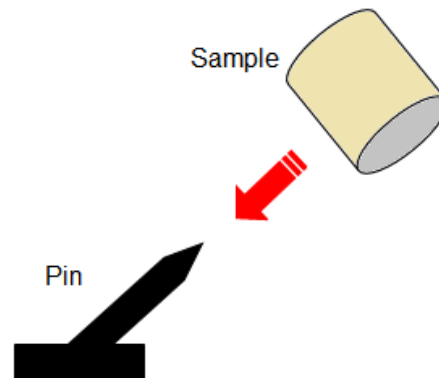

If fitted **wrongly** the sample will hit the pin on its side.

This will give **incorrect results** and may **damage** the pins.

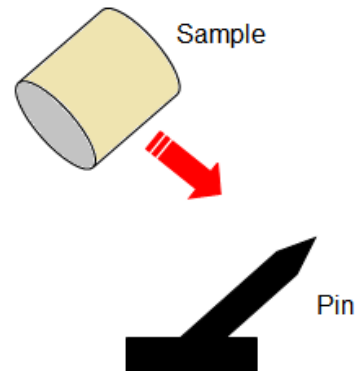

If the SnagPod has been used incorrectly inspect the pins for damage and change them if required.

Always check the pin direction when fitting a SnagPod to the Orbitor.

When changing a SnagPod from one side of the Orbitor to the other the pin direction must also be changed. See next page.

SnagPod rotating **ANTI-CLOCKWISE**.

Normal when fitted on the **RIGHT** side of an Orbitor.

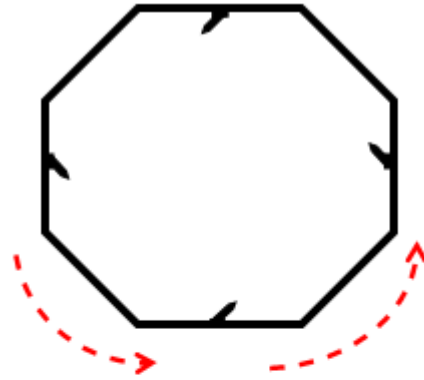

SnagPod rotating **CLOCKWISE**.

Normal when fitted on the **LEFT** side of an Orbitor.

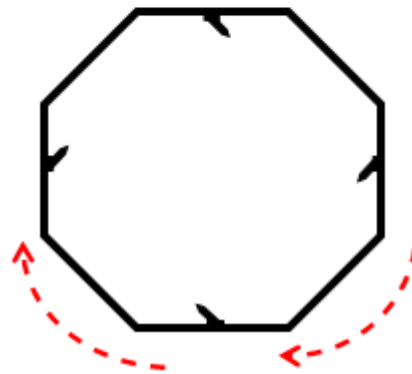

CARE & MAINTENANCE

Maintenance of SnagPod

Before each test it is essential to ensure that all fluff and debris is removed from inside the test stations, e.g., by means of a vacuum cleaning device or by using a small paint brush.

Periodically, it is necessary to clean the inside of the SnagPod when it has become contaminated by any residue from the test specimens. This should be done by wiping with a mild detergent solution. Ensure the Pod is completely dry and left for a minimum of 4 hours in Standard Atmospheric Conditions prior to use.

Care and Life of SnagPod Pins

Before each test, clean the inside of the SnagPod chamber and the pins with a vacuum cleaner or soft bristle brush and ensure they are free from visible fibres and debris. When using a vacuum cleaner it is essential to take care not to damage the pins with the nozzle of the cleaner.

Inspect the pins and replace any that show visible damage.

All pins shall be free from hooks and burrs.

Pins with rounded ends shall not be used.

The Pins have a limited life time with the expected life time being 500 tests (2000 revs at 60 rpm).

Replacement Pin Bars can be obtained by quoting the following James Heal stock code:

794-824 Snagging [Pin] Bar (each)

To replace a full set of Pin Bars in a SnagPod, then 4 x 794-824 are required.

You can use the counting grid on the next page to help record the number of tests completed in each SnagPod. Each time the SnagPod is used make a mark in the next box.

SnagPod
Serial Number



Replace Pin Bars after 500 tests.

1	2	3	4	5	6	7	8	9	10	11	12	13	14	15	16	17	18	19	20
21	22	23	24	25	26	27	28	29	30	31	32	33	34	35	36	37	38	39	40
41	42	43	44	45	46	47	48	49	50	51	52	53	54	55	56	57	58	59	60
61	62	63	64	65	66	67	68	69	70	71	72	73	74	75	76	77	78	79	80
81	82	83	84	85	86	87	88	89	90	91	92	93	94	95	96	97	98	99	100
101	102	103	104	105	106	107	108	109	110	111	112	113	114	115	116	117	118	119	120
121	122	123	124	125	126	127	128	129	130	131	132	133	134	135	136	137	138	139	140
141	142	143	144	145	146	147	148	149	150	151	152	153	154	155	156	157	158	159	160
161	162	163	164	165	166	167	168	169	170	171	172	173	174	175	176	177	178	179	180
181	182	183	184	185	186	187	188	189	190	191	192	193	194	195	196	197	198	199	200
201	202	203	204	205	206	207	208	209	210	211	212	213	214	215	216	217	218	219	220
221	222	223	224	225	226	227	228	229	230	231	232	233	234	235	236	237	238	239	240
241	242	243	244	245	246	247	248	249	250	251	252	253	254	255	256	257	258	259	260
261	262	263	264	265	266	267	268	269	270	271	272	273	274	275	276	277	278	279	280
281	282	283	284	285	286	287	288	289	290	291	292	293	294	295	296	297	298	299	300
301	302	303	304	305	306	307	308	309	310	311	312	313	314	315	316	317	318	319	320
321	322	323	324	325	326	327	328	329	330	331	332	333	334	335	336	337	338	339	340
341	342	343	344	345	346	347	348	349	350	351	352	353	354	355	356	357	358	359	360
361	362	363	364	365	366	367	368	369	370	371	372	373	374	375	376	377	378	379	380
381	382	383	384	385	386	387	388	389	390	391	392	393	394	395	396	397	398	399	400
401	402	403	404	405	406	407	408	409	410	411	412	413	414	415	416	417	418	419	420
421	422	423	424	425	426	427	428	429	430	431	432	433	434	435	436	437	438	439	440
441	442	443	444	445	446	447	448	449	450	451	452	453	454	455	456	457	458	459	460
461	462	463	464	465	466	467	468	469	470	471	472	473	474	475	476	477	478	479	480
481	482	483	484	485	486	487	488	489	490	491	492	493	494	495	496	497	498	499	500



Replace Pin Bars after 500 tests.

Guidance for Verification

The Laboratory should retain two or more reference fabrics which are representative of the fabrics tested using SnagPod. These reference fabrics should give grades of (approximately) 1-2 and 4, i.e., poor and good results respectively. The verification procedure should be carried out in each SnagPod in the Laboratory.

Then at regular intervals, but at least every six months, at least two of the reference fabrics should be tested and the results compared with the initial results and specimens.

The reference fabrics should be stored and handled under conditions that will preserve their original form and appearance. Mount the tested reference fabric specimens on white poster board.

If the verification tests show any drift from the initial test specimens then the pins should be inspected and replaced if necessary.

James Heal do not currently offer any snagging reference fabrics in our range of Test Materials.

BASIC OPERATION

Atmosphere for Conditioning and Testing

The atmosphere for preconditioning, conditioning and testing shall be used as specified in ISO 139.

Definitions of Surface Defects

Snag - undesirable surface loops of varying size on woven and knitted fabrics, often caused by catching on a sharp point or object.

Localised snagging - snags formed on the folded and tucked edge of the sample.

Protrusions - not fully formed snags.

Filamentation - A fibrous or hairy appearance due to broken filaments on the surface of a yarn or fabric is often known as filamentation.

Shiners - a thread, usually of continuous filament yarn that is generally tighter than its neighbours. In the context of this test often the tightness is a result of pulling and snagging of the yarn in the fabric.

Indentations - A concave distortion of the fabric surface, the opposite of a snag or protrusion.

Apparatus and Auxiliary Materials

Octagonal test pod with 4 rows of 20 snagging pins and capable of being rotated at 60 rpm. The pod must be sited on the test machine such that the pins are forward inclined in the direction of rotation.

Rubber tubes 70mm long, covered with woven felt as specified in BS EN ISO 12947-1-2. Rubber securing rings. These should be replaced if they become damaged or soiled, or as a minimum every 12 months.

Specimen template 140 × 140 mm (optional).

Lockstitch sewing machine capable of producing stitch type 301, lockstitch.

Recommendations:

Needle medium ballpoint (90's SUK) and 470 decitex polyester corespun thread (ticket 75's or 80's), UNLESS these cause damage or distortions to the fabric under test.

A set of nine numerically identified grading photographs representing different surface defect levels and density. Photographs shall be in half grade steps, 1 representing the worst level and 5 no change.

Assessment viewer as specified in EN ISO 12945-4, or,

ProView Universal Assessment Viewer loaded with photographs for comparative grading, available from James Heal.

Matt black assessment mask, dimensions 140 x 120 mm which has an oblong aperture of 110 x 70 mm.

Stiff brush to clean the fibrous debris off the pins and vacuum cleaning device to remove the dust and debris from the snagging pod.

Sampling and Test Specimen Preparation

Select rolls of fabric or swatches representing different rolls of the material to be tested as agreed between interested parties or take the sample length supplied and condition for a minimum of 16 hours in the standard conditioned atmosphere as described in ISO 139.

This test is normally conducted on fabric in the as received state, but cleansing may be carried out prior to testing, as agreed between interested parties.

Select two specimens from each direction of the fabric, ensuring that different length and width yarns are represented within each. Each specimen shall have dimensions of 140 x 140 mm.

Fold each specimen in half, face to face, shorter sides together, ensuring that two have the length/warp parallel to the seam and two with the width/weft parallel with the seam. Using the lockstitch machine sew a seam at the distances recommended below, from the raw edge to produce a tube of fabric.

Using a lockstitch machine, sew a seam at the following recommended distance from the raw edge:

- Woven fabrics 8 mm
- Knitted fabrics 9-10 mm

It is important that the fabric fits onto the tube such that the fabric is not too loose allowing wrinkling, nor too tight to cause distortion of the tube, and the above recommendations may need to be adjusted depending on the fabric structure.

Turn each specimen so the face is outside. Apply the tubular specimen to the tube, by hand carefully sliding it over the woven felt covering. Align the specimen seam with the join of the felt covering. Turn the raw edges of the fabric into the tube ends. Curl the rubber securing rings into a tight spiral and place inside the tube ends to secure the fabric onto the tube.

Repeat for the remaining specimens.

Test Procedure

Ensure the snagging pods are thoroughly cleaned and free from fibre debris. Care should be taken not to damage the pins with the cleaner nozzle. Check the pins periodically for damage.

Place the covered tubes in the snagging pod. Close the door securely.

Set the test apparatus for 2,000 revolutions at 60 rpm.

On completion of the test period remove the covered tubes from the pod. Release securing rings and remove the specimens from the tubes by cutting along the stitching line, do not trim the specimens at this stage.

Assessment and Classification

Using the assessment viewer, place a tested specimen on one side of the viewer. Place the mask over the specimen, carefully aligning the aperture so the tested area is visible to the assessor, ignoring any localised snags or defects on the folded edge. Position each photograph in turn next to the masked specimen, or select the photographs from the touchscreen if using ProView, and visually compare and to determine which photograph most closely represents the level of surface defects exhibited. Record the numerical value of the photograph. This numerical rating is the grade of assigned for each specimen.

Note: Localised snags and defects on the folded edge are ignored.

In addition to the numerical rating assigned to each specimen, the surface defect type/s will be classified.

Note: more than one defect type may apply.

Classification of Surface Defects

Defect Type	Defect Description
A	Snagging only no other defects
B	Protrusions, i.e., not fully formed snags
C	Indentations.
D	Shiners or other distortions of fabric structure that are either in close proximity to any snag loops and or not associated with any snag loop.
E	Visible defects due to colour contrasts, these often occur in printed, colour woven or colour knitted fabrics.
F	Filamentation.
G	Any other defects specific to the fabric type and which detract from the original surface appearance, a description shall be included when reporting.

The test specimens should be mounted on card along with a piece of original fabric for reference. The test specimens should be trimmed to remove the seam allowance and any localised snagging or defects, to the dimensions 115 x 70 mm.

Test Report

The test report shall include at least the following information:

- a) The individual specimen grades
- b) Any other surface defect that detracts from the original appearance, using defect types
- c) Any deviations from this standard

TECHNICAL DATA

EU Conformity

- Machinery Directive 2006/42/EC
- Low Voltage Directive (LVD) 2014/35/EU
- Electromagnetic Compatibility (EMC) Directive 2014/30/EU
- Waste Electrical and Electronic Equipment Recycling (WEEE) Directive 2012/19/EU
- Restriction of Hazardous Substances (RoHS) Directive 2011/65/EU

SERVICE & CALIBRATION

Servicing and calibration is available Worldwide - Contact our Service & Calibration Department for further details. The James Heal Service & Calibration service is a totally comprehensive, worldwide support programme.

When you buy instrumentation from us, it is the beginning rather than the end of a relationship.

Our aim is simple: to provide precisely the services you need to maintain and protect the value of your investment.

For any enquires you may have regarding your instrument please contact James Heal Service & Calibration by e-mail, phone or fax.

In all communications please quote the serial number of your instrument and the software version number, e.g., 1616/16/1001 and V1.00.

James Heal Service & Calibration contact details:

TELEPHONE	+44 (0) 1422 366355
E-mail	Halifaxinformation@pptgroup.com
Internet	http://www.james-heal.co.uk

REVISION HISTORY

See front cover for publication number, e.g., 290-726-D

Rev	Date	Originator	Details of revision
A	15.10.03	LE	First release
B	7.8.12	LE	
C	20.12.13		
D	5.1.17	CB	Touchscreen image ProView Orbitor EU conformity
E	23.01.19	SEW	Template size correction
F	24.08.2023	PG	Added section: Care and Life of SnagPod Pins